

$$C_n = 10^N (0.1/D)^{2.08}$$

clean room filters - a guide

Camfil Farr

Technical information

Jan Gustavsson, Technical Director, Camfil

Camfil Farr - clean air solutions



CLEAN ROOM FILTERS © Jan Gustavsson, Camfil ab

Table of contents	page
CLEAN ROOM	3
CONTAMINANTS	4
ABSOLUTE FILTER	4
Filter material	4
ABSOLUTE FILTER designations	5
ABSOLUTE FILTER CLASSIFICATION	5
Performance classes (IES-RP-CC001.3)	5
Construction classes (IES-RP-CC001.3)	6
Eurovent Classes	6
DIN 24184, Classes of "SCHWEBSTOFF"-filter	6
EN 1822:1999 HEPA and ULPA filters	7
Test aerosols	8
CHEMICAL FILTERS	9
CHEMICAL CLASSIFICATION	10
LAMINAR FLOW	11
Federal Standard 209 F	11
IES-RP-CC-002.2:1999	11
BS 5295: 1989	11
AFNOR NFX 44-102	12
Nordic R ³ Association	12
SUMMARY of Norms/Standards	12
Future	12
ROOM CLASSIFICATION	13
ISO 14644-1, CLEANROOMS	13
US Fed Std 209E	14
Number of sample locations required	14
Old US Fed Std-209D, 1988	15
France AFNOR NFX 44-101, 1981	15
Germany VDI 2083, 1990	15
GGMP PIC/EEC 1989	15
Japan JACA No 24 - 1989	15
England BS 5295 - 1989	15
Summary - Classification	16
TESTING OF INSTALLATIONS	17
Leaks	17
DOP Test aerosol	18
DEHS-test aerosol	18
Emery 3004 test aerosol	18
PARTICLE COUNTERS	19
Type of aerosol	20
Number of particles	20
Noise level	20
SYSTEM COMPONENTS	21
Filter	21
Outdoor air	21
Internal dust generation	21
CHOICE OF FILTER - CALCULATIONS	21
Unidirectional flow room with 100 % outdoor air	21
Unidirectional flow room with 100 % recirculated air	22
Unidirectional flow room with recirculated air	22
Nonunidirectional airflow system	22
DIAGRAMS 1-9 BASICS	24

CLEAN ROOM FILTERS

The last few years have seen a striking change in the approach to HEPA, ULPA and CHEMICAL filters. The changes have influenced choice of material, testing methods and the manufacture of filters, as well as the relationship between the supplier and user.

The requirements of the environment in clean rooms have increased significantly. The electronics industry must design and construct systems today which will also meet the needs of the future. Development is rapid and we know that criteria for particulates and gases will be of decisive importance. The HEPA, ULPA and CHEMICAL filters of the future are already needed now.

Consequently, the microelectronics industry has as such led the development and been the driving force behind most of the innovations and improvements. But the results have benefited the rest of industry too.

CLEAN ROOM

The "Heart" of the Clean Room is the filter, but there are a number of considerations regarding room classification, choice of filter and how the filters influence the environment.

What is class 10? What is a 0.1 μm filter? Do we need "miracle" filters for higher requirements?

A filter is used wherever there is a need and a necessity for a high level of clean air. The technique of filtration to any level of clean air has been possible for a long time and has been relatively inexpensive and simple.

Today the requirements is very much concentrated to what happens within the semiconductor industry. The number of transistors on the "chip" is increasing at a rate of 50-60% per year at the same time as the line width and thickness are reducing by 20-30% per year.

The critical particle size is half of the line width and the critical particle concentration decrease down to class 1 for the critical particle sizes. Today we can find 256Mb memories based on 0.25 μm size or 250nm technology. There are existing solutions for 180nm technology, but for 150 and 130nm there are very few solutions. For 130nm and smaller there are no known solutions and in some cases there are also physically limits.

Table 1. Development of memory capacity and line width in integrated circuits. /1997 Semiconductors Roadmap /.

Year	Memory (bits/chip)	Line width (nm)	Critical	
			size (μm)	Concentration ^{*)} particles/m ³
1997	256 M	250	0.125	27
1999	1 G	180	0.090	12
2001	1 G	150	0.075	8
2003	4 G	130	0.065	5
2006	16 G	100	0.050	2
2009	64 G	70	0.035	1
2012	256 G	50	0.025	1

^{*)}Number of particles larger than critical size.



Figure 1. Example of a Clean room.

CONTAMINANTS

Most modern industries for the manufacture of integrated circuits (chips) are designed to filter small particulates at extremely low levels. They have not been designed to deal with molecular impurities (gases, vapours).

It was known at an early stage that metallic impurities such as Na, Fe, Cu, Zn, Al, ... can cause electrical breakdown in thin electrical insulating layers and current leakage in P and N circuits.

At the start of the 1990s, the microelectronics industry discovered that phosphorous impurities and boron could cause similar phenomena and doping of P circuits. The transistor's capacitance as a function of the voltage changes and can produce defective circuits. External gases such as NO_x , SO_2 , KCl, NaCl, hydrocarbon impurities and gases internal to the plant or from the process, HF, HCl, NH_3 , P and, above all, B must be controlled at extremely low levels.

The effect of molecular impurities is not fully documented but their importance is growing and is a crucial factor for future manufacture of integrated circuits.

It has been shown that quite a number of the impurities derive from conventional HEPA and ULPA filters at a very low level. The glass filter material normally contains a high level of boron, which can be degassed. Adhesive can contain a high level of phosphorous or other impurities in order to create a fire-resistant material. The test aerosol may evaporate from the filters and impurities from the manufacturing process may be detected at a later stage. This places entirely new demands on particulate filters in the form of choice of material, testing, manufacture and documentation. At the same time, an ever increasing importance is being placed on filters for separating gases.

The demand for cleaner environments has, together with the development of particle counters, led to the older test methods and classifications being modified or adjusted to suit the new conditions. This mixture of old and new conditions can be difficult to understand.

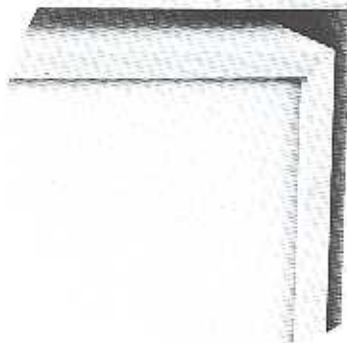

Figure 2. An Absolute filter for a clean room.

ABSOLUTE FILTER

Absolute filters were developed during the second World War and the definition of an Absolute filter is "... a filter with minimum DOP efficiency of 99.97 %".

The DOP method tests the penetration of the filter by $0.3 \mu\text{m}$ particles, which was considered the most difficult particle size for a filter to collect. The "critical" particle size depends on filter media performances and velocity. With fibers and media used today the most difficult particle size to collect is about 0.1 to $0.2 \mu\text{m}$.

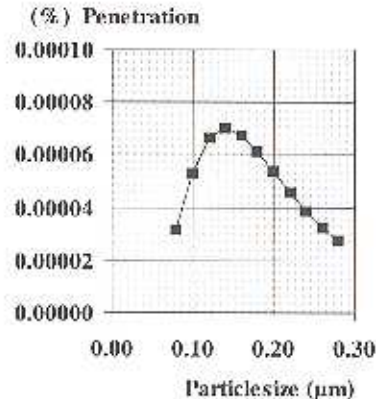

Figure 3. Penetration vs. particle size for an ULPA filter. The most penetrating particle size is ca. $0.13 \mu\text{m}$.

The development of particle measuring equipment, together with fractional efficiency requirements have led to new test methods for Absolute filters. One example of this is the Laser Particle test method and the test with the most penetrating particle size (MPPS) in EN 1822.

FILTER MATERIAL

HEPA and ULPA filters are generally made of glass fibre material which contains approx. 10% boron which may be released in the presence of moisture or in contact with hydrogen fluoride (HF). Although the concentrations from this and other outgassing molecules are extremely low it concerns the advanced production in semiconductor industry. Fibre manufacturers have over the last few years managed to reduce the boron content to a hundredth of the standard value, and a new type of filter medium has been developed.

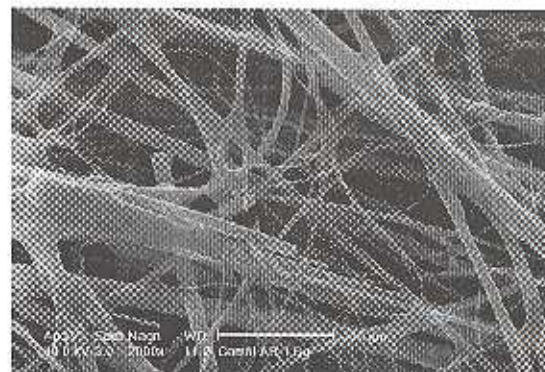

Figure 4. "Boron free" glass fiber media from a unused Absolute filter.

In parallel with this, membrane filters have also undergone development. It is now possible to manufacture ULPA filters from Teflon (PTFE) material. The advantage of this material is that it does not contain substances which may outgas or evaporate. It is a strong and clean material and emits only few particulates during manufacture or use.

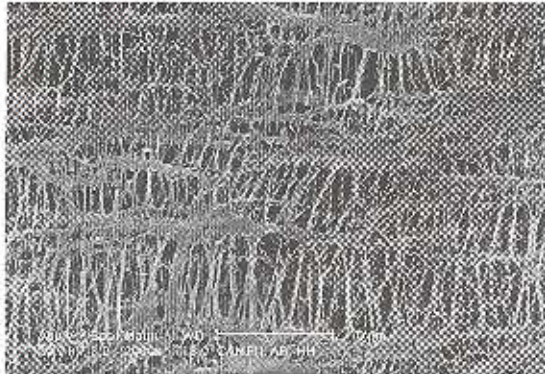

Figure 4. Example of PTFE filter media.

ABSOLUTE FILTER DESIGNATIONS

Today we can find different designation of Absolute filters depending on efficiency, test method and country of origin.

HEPA filter (High Efficiency Particulate Air filter) is more or less an international designation of "A throw-away extended media dry type filter in a rigid frame having a minimum particle collection efficiency of 99.97 % for 0.3 μm thermally generated DOP particles or specified alternative aerosol, and a maximum clean filter pressure drop of 2.54 cm water gage, when tested at rated air flow capacity" (IES-RP-CC001.3).

In the same standard and in Reg. Guide 1:52 (Nuclear filtration System) or NSF 49 (hazardous biological particulate) the HEPA filters should besides efficiency meet all constructions and testing requirements outlined in MIL-F-51477 or MIL-F-51068.

HESPA filter (High Efficiency Sub micrometer Particulate Air Filter) is a designation used in England for filters with higher Efficiency than 99.95 % according to Sodium Flame (BS 3928)

ULPA filter. In USA ULPA is used to designate a filter having a minimum collection efficiency of 99.999 % for particles in the size range of diameters 0.1 - 2 μm . (IES-RP-CC001.3).

In Europe an ULPA filter is defined in EN 1822 and means a filter with more than 99.9995 % efficiency on most penetrating particle size

SCHWEBSTOFF-filter. In Germany, filters with high efficiency were called "SCHWEBSTOFF" filters and

tested according to DIN 2418 with paraffin oil. The filters were classified in 3 classes: Q, R or S. Today the European designation of HEPA and ULPA filters is used.

MIKROFILTER is used in Nordic countries to signify Absolute filters.

VRPA filter - Very High Efficiency Particulate Air Filter

VLSI filter - Very Large Scale Integrated Circuit Filters.

0.1 μm - or 0.05 μm filter - Normally this stands for a filter with a high efficiency against such particles.

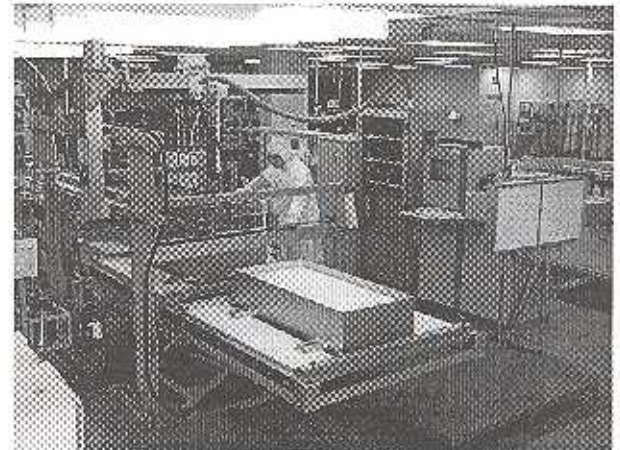

Figure 5. HEPA and ULPA filters for higher requirements have to be produced in clean rooms.

ABSOLUTE FILTER CLASSIFICATION

Performance classes (IES-RP-CC001.3)

The Institute of Environmental Science, (IES), has classified HEPA filters in six performance classes (type A, B, C, D, E and F) and in five construction classes - grade 1 to 6.

Type A filter - a filter with a minimum efficiency of 99.97 % on 0.3 μm particles at rated air flow.

Type B filter - a filter with a minimum efficiency of 99.97 % on 0.3 μm particles tested at 100 % and 20 % of rated air flow.

Type C filter - a filter with a minimum efficiency of 99.99 % on 0.3 μm particles and leaktested (scanned). No photometer reading downstream of the filter greater than 0.01 % of the upstream concentration is acceptable.

Type D filter - a filter with a minimum efficiency of 99.999 % on 0.3 μm particles and leaktested (scanned). No photometer reading downstream of the filter greater than 0.01 % of the upstream DOP concentration is acceptable.

Type E filter - a filter designed, constructed, and tested in strict accordance with MIL-F-51477 or MIL-F-51068.

These filters are normally for use in air filtering systems involving toxic-chemical, carcinogenic or hazardous biological particulate.

Type F filter - the minimum filter efficiency for this type is 99.999 % on 0.1 - 0.2 μm particles (Particle counter test IES-RP-CC007)

FILTER	MAXILAM
TYPE	MXLGS 1148x548
SERIAL NO	9201002
TEST FLOW	790 m³/h 90 Pa
EFFICIENCY	0.12μm 99.999942%

Figure 6. Example of a test result on an ULPA-filter.

Construction classes (IES-RP-CC001.3)

Grade 1 (MIL-F-51068) filter

Fire resistant construction throughout. Filter units should meet the requirements of MIL-F-51068. It's used primarily in military equipment, nuclear cleaning systems and severe-duty industrial applications.

Grade 2 (UL 586) filter

Fire-retardant construction throughout and meets additional moisture and low temperature exposure test.

Grade 3 (UL-900 Class 1)

The filter when clean does not contribute fuel when attacked by flame and emits only negligible amounts of smoke.

Grade 4 (UL-900 Class 2)

The filter, when clean, burns moderately when attacked by flame or emits moderate amount of smoke or both.

Grade 5 (FM Listing)

This type of filter is constructed with fire retardant material and has been qualified for use in clean room ceiling or wall system. Qualification testing is performed on the complete system including frame, sealant and filterunits.

Grade 6 (non fire retardant construction)

For noncritical or nonsafety related applications.

Eurovent Classes

Eurovent has classified high efficiency filter in five grades, EU10 to EU14 based on efficiency according to the Eurovent 4/4 test method (Sodium Flame, 0.65 μm particle size).

This Eurovent Classification has not been used very much. The test method and classification do not cover the demands today and has been replaced by the EN 1822.

Table 2. Classification based on Eurovent 4/4

Filter class	Initial Efficiency, E_i %	Initial Penetration %
EU10	$95 \leq E_i < 99.9$	$5 \geq P > 0.1$
EU11	$99.9 \leq E_i < 99.97$	$0.1 \geq P > 0.03$
EU12	$99.97 \leq E_i < 99.99$	$0.03 \geq P > 0.01$
EU13	$99.99 \leq E_i < 99.999$	$0.01 \geq P > 0.001$
EU14	$99.999 \leq E_i$	$0.001 \geq P$

DIN 24184. Classes of "SCHWEBSTOFF"-filter Dec. 1990.

In Germany filters were tested with paraffin oil (0.3-0.5 μm particles sizes) and classified in the classes Q, R or S according to following table. The method and classification is replaced by CFN EN 1822.

Table 3. Classification to the old German DIN 12484

Class	Max. penetration paraffin oil %
Q	15
R	2
S*	0.03

*Free from visible pinholes during oil mist test

Note that the DOP-test uses 0.3 μm particles and EUROVENT 4/4 uses 0.65 μm particles in determining the filter efficiency. The German classification was based on particles mainly between 0.3 to 0.5 μm . The same filter gives different efficiency values depending on the test method. The DOP penetration is for instance normally two times higher than the penetration measured according to Sodium Flame. From middle of 1999 all the different standards in different countries are replaced by the European EN 1822.

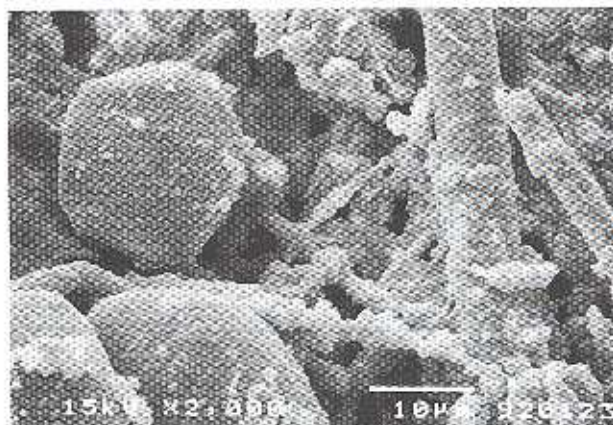

Figure 7. Dust on the inlet side of used Absolute filter media.

EN 1822:1999 HEPA and ULPA filters.

To meet the high tech demands there is a need for new test methods and classification of Absolute filters. CEN, the European standardisation body for standards, has launched EN 1822 for classification and testing of HEPA and ULPA filters. The method and classification is based on the efficiency for the most penetrating particle size (MPPS).

The system is based on letters and figures on the same way as for coarse and fine filters. H stays for HEPA and U for ULPA filters. The filters are then divided into 8 classes from H10 to U17 depending on efficiency of the most penetrating particle size and the size of the leaks. The Penetration of a leak shall normally not be larger than 5 times the overall Penetration of the filter. (Not for U17-filters, where the ratio is 20)

Table 4. EN 1822 Classification of HEPA and ULPA filters.

EN 1822 Class	Efficiency MPPS (%)	Leak test local (%)	Leak test method
H10	85	-	-
H11	95	-	-
H12	99.5	-	-
H13	99.95	99.75	visible/scanning MPPS
H14	99.995	99.975	scanning MPPS
U15	99.9995	99.9975	scanning MPPS
U16	99.99995	99.99975	scanning MPPS
U17	99.999995	99.9999	scanning MPPS

H13 and H14 filters and filters not suitable for scanning could be tested according to the German DIN 24184 smoke test.

EN 1822 is based on the German DIN 24183 standard, which used the letters EU instead of H or U. To avoid mixture with the Eurovent designation CEN decided to use H and U.

Figure 8. Principle drawing of a "Laser Scanner" for most penetration particle size test according to EN 1822

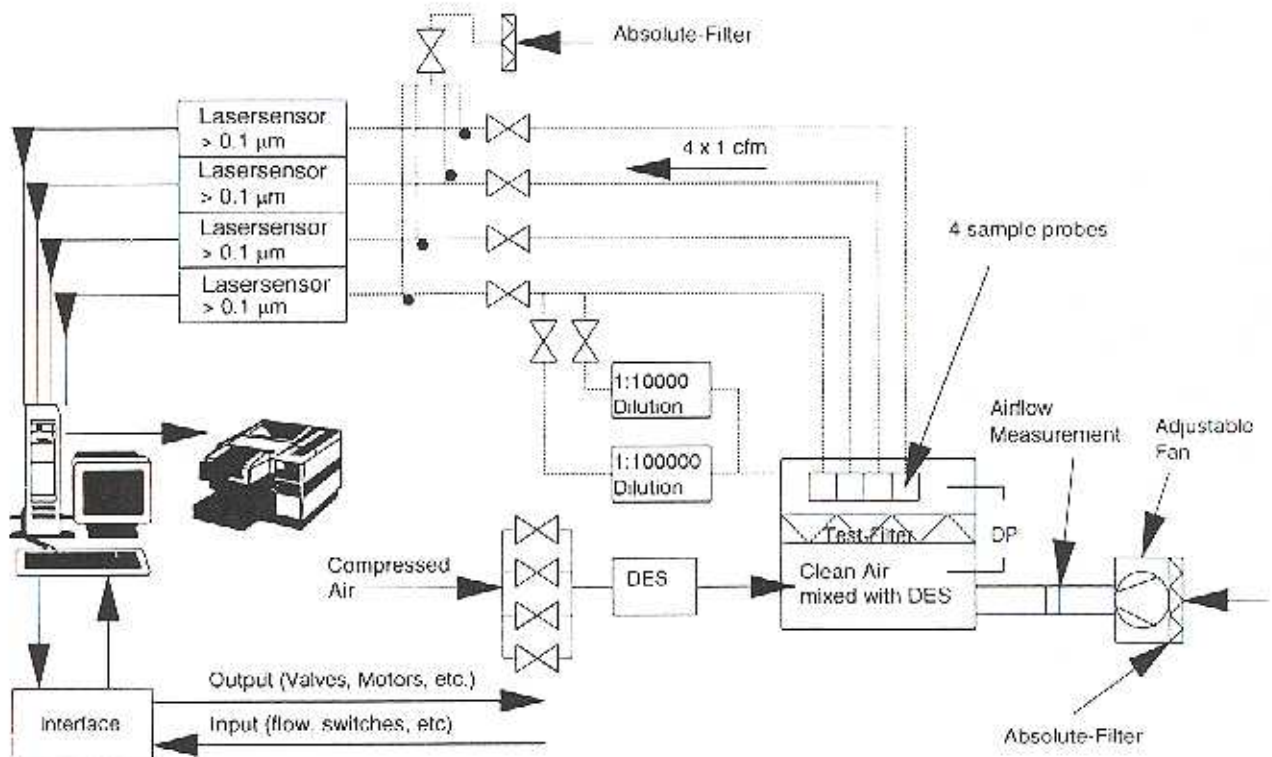

TEST AEROSOLS

Discussions on the cancer risk surrounding DOS or DEHS has resulted in increasing use of Emery 3004 as a test aerosol both for production and *in situ* testing.

Emery 3004 is a synthetic hydrocarbon compound which is used as a synthetic lubricant and which has proved to be a good replacement for older test aerosols, as well as being cheap, non-corrosive and easy to work with.

DOS or DEHS or, in certain contexts, salt (NaCl), which has long been used for this purpose, is strictly prohibited for testing filters for the electronics industry. Solid latex or silicon particulates are chosen instead.

Liquid particulates such as DEHS are easy to produce in the high concentrations needed for testing ULPA filters.

Latex or silicon particulates are solid particulates which are normally dissolved in water or sprayed out in the filters. The concentration must be sufficiently low that each drop of water contains just one particulate. The water must evaporate before the particulate reaches the filter. This has meant certain limitations to generating particulates in sufficiently high concentrations. However, equipment is now commercially available and latex or silicon particulates will probably replace the liquid particulates altogether, both in production and on the field.

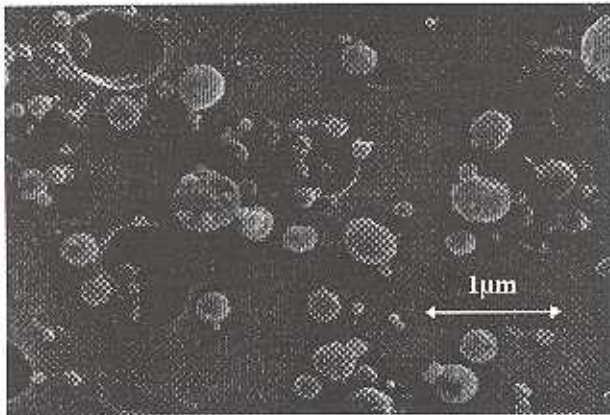

Figure 9. *Solid SiO₂ particles for testing HEPA and ULPA filters*

CHEMICAL FILTERS

Control of gaseous impurities is a condition for the manufacture of integrated circuits of the future. Chemical filters are used to clean incoming exterior air of hydrocarbon compounds, sulphur dioxide, nitrous gases and ozone. Chemical filters are also needed in circulation air and directly above certain processes in order to remove impurities being released as gas from the material in the clean room or from people and processes. Ammonia from people, for example, will be a problem in one part of the process and a chemical filter is needed to capture gases of this type.

Consequently, a number of different gas filters will be necessary in order to capture specific gases. As the pressure loss in the system as a whole must be kept low, a new type of chemical filter has been developed. Normally, the concentrations of the gases are low and the filters do not need to have such a high capacity as if they were to filter exterior air. It is, on the other hand, important that the degree of separation is high and maintained over a long period.

A modern chemical filter may be composed of porous foamed polyurethane where the walls or the cavity are coated with small, spherical, carbon balls. The porous foam gives low pressure drop and good separation as all the carbon is directly accessible to the gases passing through. Specific substances can be separated by using different impregnations in the chemical filter.

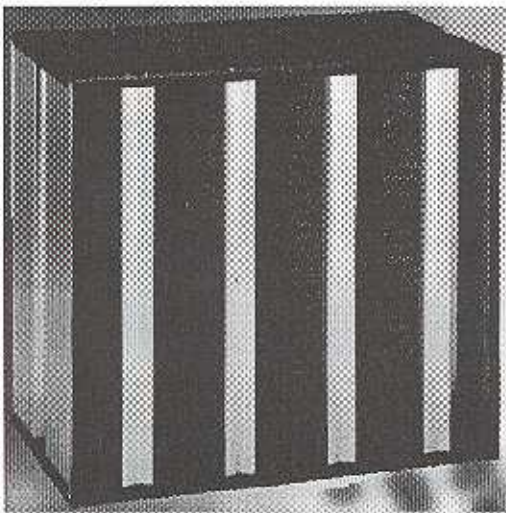

Figure 10. Chemical filter of celltype. For high airflows and low pressure drops.

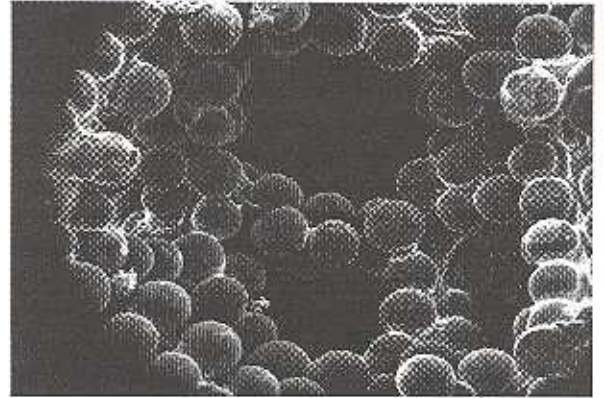

Figure 11. Structure of chemical filter material with one layer of hard spherical carbon balls inside foamed polyurethane.

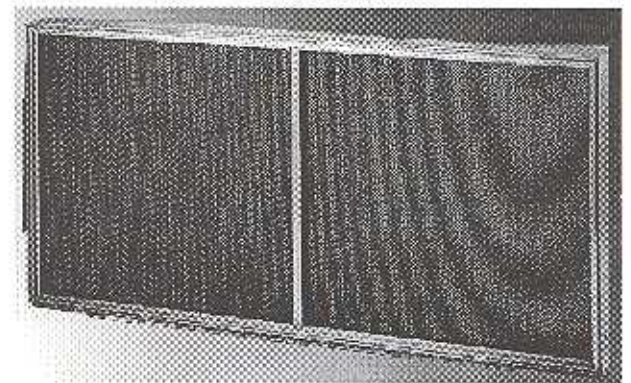

Figure 12. Chemical filter for laminar flows and low pressure drop.

CHEMICAL CLASSIFICATION

Most modern industries for the manufacture of integrated circuits have to be designed to deal with airborne molecular contamination (AMC) as gaseous and vapours.

It was known at an early stage that metallic impurities such as Na, Fe, Cu, Zn, Al, ... can cause electrical breakdown in thin electrical insulating layers and current leakage in P and N circuits.

At the start of the 1990s, the microelectronics industry discovered that phosphorous impurities and boron could cause similar phenomena and doping of P circuits. The transistor's capacitance as a function of the voltage changes and can produce defective circuits. External gases such as NO_x, SO₂, KCl, NaCl, hydrocarbon impurities and gases internal to the plant or from the process, HF, HCl, NH₃, P and, above all, boron (B) must be controlled at extremely low levels.

Chemical concentrations in clean rooms could be 0.01 to 10 ng/m³, which is more than 1000 times higher than the particle concentration.

The effect of AMC (airborne molecular contaminations) is not fully documented but their importance is growing and is a crucial factor for future manufacture of integrated circuits. The concentrations of AMC in air is often expressed in weight (ng/m³) or as volume of gas in the air

- ppm parts per million (10⁻⁶) or
- ppb parts per billion (10⁻⁹) or
- ppt parts per trillion (10⁻¹²)

AMC's are becoming more and more important and in SEMI F21-95 gaseous contaminations are classified in a system equal to the particle cleanliness system. Table 5.

Four different critical categories of AMC are defined; Acids(A), Bases(B), Condensables(C) and Dopants(D). The class is designated by the letter "M" and the category A, B, C or D followed by an integer indicating the maximum total gas-phase concentration in parts per trillion molar (pptM). For example, a cleanliness class MA-1 000 has a maximum allowable total concentration of 1 000 pptM of acid gaseous.

Table 5. Classification according to SEMI Standard F21-95.

Contamination Category	Classification				
	1 pptM	10 pptM	100 pptM	1 000 pptM	10 000 pptM
Acids	MA-1	MA-10	MA-100	MA-1 000	MA-10 000
Bases	MB-1	MB-10	MB-100	MB-1 000	MB-10 000
Condensables	MC-1	MC-10	MC-100	MC-1 000	MC-10 000
Dopants	MD-1	MD-10	MD-100	MD-1 000	MD-10 000

SEMATECH has made a forecast for permissible AMC concentrations in the 0.25µm logic process. The most sensitive steps are "Pre-Gate oxidation", "Salicidation", "Contact Formation" and "Photo-lithography". Table 6.

Acids and bases are corrosive gaseous whose chemical reaction characteristics are those of an electron acceptor and electron donator, respectively. The contact formation and Salicidation are most sensitive to acids while the Photolithography is most sensitive to bases.

Condensables are substances having a boiling point above room temperature, which means that they can condense on a surface.

Dopants are chemical elements which modify the electrical properties of a semiconductive material. Pregate oxidation is extremely sensitive to dopants.

Table 6. Sematec forecast for 0.25µm logic process

Step	Max. Sit time(h)	AMC limits in pptM			
		MA	MB	MC	MD
Pre-Gate oxidation	4	13 000	13 000	1 000	0.1
Salicidation	1	180	13 000	35 000	1 000
Contact Formation	24	5	13 000	2 000	100 000
Photolithography	2	10 000	1 000	100 000	10 000

LAMINAR FLOW

In the field of clean room technology is laminar flow, or the parallel streaming of air, an important factor for the effective removal of contaminants. When variations in laminar flow is nonunidirectional, there is a substantial risk that contaminated air will be inducted into the flow and that the movement of contaminants across the flow of air will increase. Most standards for laminar flow systems take this into account and impose definite requirements on velocity distribution. What good is a high efficiency filter if its filtration capacity is ruined by uneven air distribution? Uneven distribution can be caused by a poor designed ventilation system or by uneven flow of air from the filter.

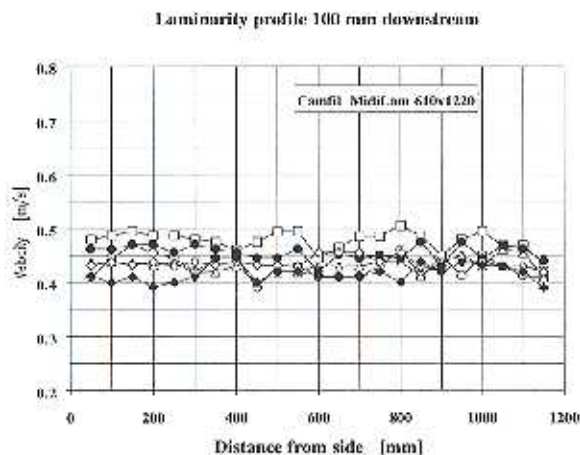

Figure 13. This figure shows the air flow velocity 100 mm downstream of an Absolute filter at different points. The air distribution will be within most specified norms.

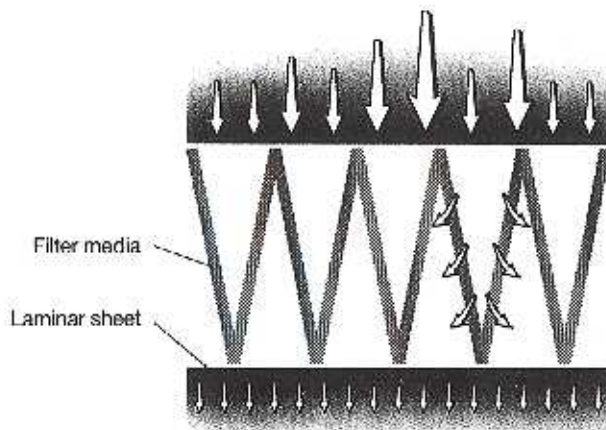

Figure 14. The good air distribution is achieved with the patented v-shape of the pleats and the laminator on the filter outlet.

FEDERAL STANDARD 209 E.

Airborne Particulate Cleanliness controlled classes in Clean Room and Clean Zones.

Instead of laminar flow and turbulent flow Fed Std 209E defines the expressions *unidirectional* airflow and *nonunidirectional* airflow

Unidirectional airflow. An airflow having generally parallel streamlines, operating in a single direction, and with uniform velocity over its cross section; previously referred to as *laminar* airflow.

Nonunidirectional airflow. An airflow which does not meet the definition of unidirectional airflow; previously referred to as *turbulent* or *non-laminar* airflow.

IES-RP-CC-002.2:1999

Institute of Environmental Sciences Recommended Practice for Unidirectional Flow Clean-Air Devices

The standard recommends procedures and requirements for clean air devices and specifies the following acceptance of laminarity 30 cm downstream of the HEPA or ULPA filter

6.1.6 Acceptance

<The customer should specify average measured clean-air velocity, typically 0.45 ± 0.05 m/s

BS 5295: 1989

Environmental cleanliness in enclosed spaces

In appendix D.3 of Part 2 of the standard the following is said about laminarity: "...some high efficiency filters may require certification of velocity uniformity across the filter face. If such certification is required by the purchaser, then the test method, average velocity required and mean deviation thereof should be specially defined by the purchaser and agreed with the supplier."

The *old Version of BS 5295* from 1976 specified both velocity and uniformity as : Part 1. A.2.11.3.2 Filter bank air flow: "...Similarly when using a vane anemometer to measure the air velocity at the filter face, a series of readings should be taken across the face in the horizontal and vertical planes with the anemometer 100 mm downstream of the face."

5.1.2 The air velocity shall be:

- horizontal flow $0,45 \pm 0,1$ m/s;
- vertical flow $0,30 \pm 0,05$ m/s.

AFNOR NFX 44-102,

Encintes à Empoussièrement Controlé

3.3 Salle propre à écoulement laminaire

The norm specify an average velocity 0.4 m/s for a clean room with vertical flow and 0.5 m/s for horizontal. The readings shall be less than $\pm 20\%$ of the average value.

3.5 Pose dépoussiéré à écoulement

The average velocity is generally between 0.3 and 0.6 m/s and the individual values shall be within $\pm 20\%$ of the average.

5.3.2.3 Cas de la salle à écoulement laminaire aire

Velocity shall be less than $\pm 10\%$ of average (as par 3.5) measured 20 cm downstream of the filter or protective grille.

NORDIC R³ ASSOCIATION

Norm for open LAF units

The measurement shall be taken 100 to 150 mm downstream of the HEPA filter.

13.3.3 Requirements (R³)

Unless other wise agreed, all measurement values shall be within the $0.45 \pm 20\%$ m/s range. No clear systematic variations in air velocity, such as an area with high or low air velocity, may be permitted.



Figure 15. *Laminar flow Bench, where laminarity could be of great concern*

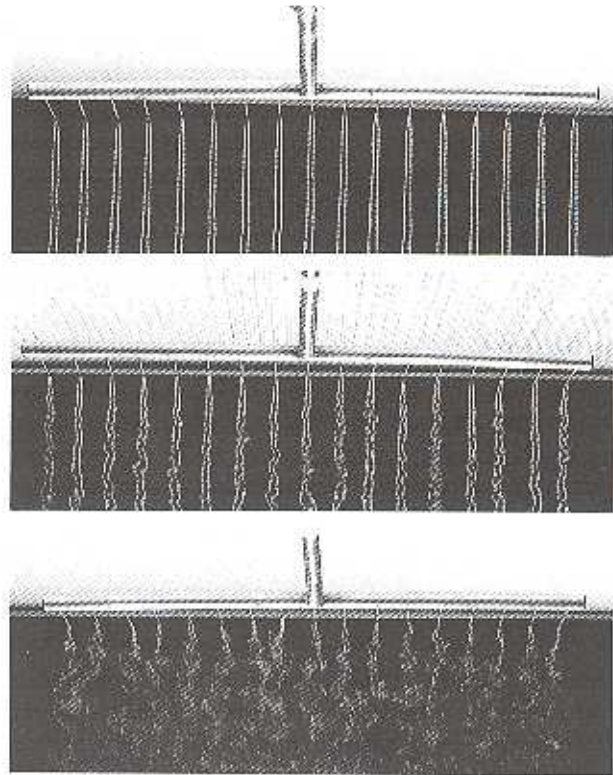

Figure 16. *Smoke traces demonstrating of laminar flow from different filters. The upper filter with the laminar sheet has parallel stream, whilst the filter with separators has more turbulence. The bottom filter represents a typical minipleat filter with very heavy turbulence*

SUMMARY OF NORMS/STANDARDS

Several standards stipulate an average air velocity of 0.45 ± 0.1 m/s. In most cases the individual readings shall be less than $\pm 20\%$ of the average velocity.

The position at which each velocity is measured varies, however the norm is from 100 mm up to 200 mm downstream of the filter face.

The number of measurement points varies from the entire face to individual points spaced 300 mm apart.

FIGURE

The demands of laminarity increase with the higher efficiency demands and more and more endusers specify less and less deviation of velocity.

ROOM CLASSIFICATION

The most well-known classification system comes from Federal Standard 209 which was published for the first time in 1963 in the USA. Since the first issue there have been five revisions and from September 1992 Fed Std 209E is in use.

The 209 standard is the most recognised clean room standard for classifying different cleanliness classes. The versions were always based on the number of particles equal or larger than 0.5 µm in one cubic foot air while the latest 209E is based on SI (metric units).

In spite of the world-wide use of the 209 standard many countries, companies and societies have made their own versions. All have used the metric system, but refer to different systems for classification of cleanliness. Britain uses letters of Alphabet, France has numbers, Germany uses the logarithm of 1.0 µm particles per m³ while Japan uses the same system based on 0.1 µm counts. In most cases there are crossover points to 209.

ISO is working on clean room standards and the ISO/DIS 14644-1. *Cleanrooms and associated controlled environments Part 1: Classification of airborne particulates* has been submitted to ISO for approval as final draft standard (FDIS).

ISO/DIS 14644 part 2 (*Testing...*) and part 4 (*Design...*) of have reached draft international stage, while other parts are under work.

Due to ISO work in this field most of the national standards will disappear in the future.

ISO 14644-1. CLEANROOMS...

Classification of airborne particulates

The ISO standard from 1999 describes that the cleanliness shall be designated by a classification number, *N*. The maximum permitted concentration of particles, *C*, for each considered particle size, *D* is determined from the formula

$$C = 10^N (0.1/D)^{2.08} \quad \text{Particles/m}^3$$

where

C is the maximum concentration in (particles/m³)

N is the ISO class (maximum 9)

D is the particle size in µm

0.1 is a constant (the reference size) in µm

The ISO classification number shall not exceed 9 but intermediate ISO classifications may be specified with 0.1 as the smallest permitted increment of *N*.

The Table 7 presents selected airborne particulate cleanliness classes and the corresponding particle concentrations for particles equal to and larger than the considered particles shown.

The method for determination of classification and the statistical approach are described. The minimum number of sampling points are the square root of the cleanroom area in m² (rounded up to a whole number). The sampled volume should be sufficient at each location that a minimum of 20 particles would be detected if the concentration of the relevant class were at the class limit for the largest considered particle size.

The cleanroom has met the acceptance criteria if the average particle concentration meets the required class limits at an 95% upper confidence limit. The standard gives examples of detailed calculations at different conditions.

Table 7. Airborne particulate cleanliness classes for clean rooms according to ISO 14644-1:1999
The classes shall be defined in one or more of the occupancy states, as built, at rest or operational.

Class	Max. concentration (particles/m ³) for particles equal to and larger than the considered sizes shown below					
	0.1 µm	0.2 µm	0.3 µm	0.5 µm	1 µm	5 µm
ISO Class 1	10	2				
ISO Class 2	100	24	10	4		
ISO Class 3	1 000	237	102	35	8	
ISO Class 4	10 000	2 370	1 020	352	83	
ISO Class 5	100 000	23 700	10 200	3 520	832	29
ISO Class 6	1 000 000	237 000	102 000	35 200	8 320	293
ISO Class 7				352 000	83 200	2 930
ISO Class 8				3 520 000	832 000	29 300
ISO Class 9				35 200 000	8 320 000	293 000

US Fed Std 209E

The standard is based on SI (metric units) and describes the airborne particulate cleanliness classes M1, M1.5, ..., M7 according to the following table.

209E Class	Max. particles/m ³				
	0.1 µm	0.2 µm	0.3 µm	0.5 µm	5 µm
M 1	350	75.7	30.9	10.0	-
M 1.5	1 240	265	106	35.3	-
M 2	3 500	757	309	100	-
M 2.5	12 400	2 650	1 060	353	-
M 3	35 000	7 570	3 090	1 000	-
M 3.5	-	26 500	10 600	3 530	-
M 4	-	75 700	30 900	10 000	-
M 4.5	-	-	-	35 300	247
M 5	-	-	-	100 000	618
M 5.5	-	-	-	353 000	2 470
M 6	-	-	-	1 000 000	6 180
M 6.5	-	-	-	3 530 000	24 700
M7	-	-	-	10 000 000	61 800

The conditions of test of the clean room shall be recorded as "as built", "at rest", "operational" or otherwise as specified.

The concentrations limits are based on the table but the following equation could, approximately, be used for intermediate classes

$$\text{Particles/m}^3 = 10^M(0.5/d)^{2.2}$$

where

M = is the class (1, 1.5, ..., etc.)

d = is the particle size in µm

The classification is based on the 0.5 µm particle size, but the verification of cleanliness classes could be made by other sizes. The class should always be followed by verification size. For example:

- class M 3 (at 0.5 µm) or
- class M 3 (at 0.3 µm and 0.5 µm)

U descriptor

New in Fed Std 209E is that a U descriptor could be used to express the concentration of ultra fine particles (0.02 µm and larger). The U descriptor may be used alone or as a supplement to the specification of cleanliness classes. For example:

- Class U(20) describes cleanliness class with not more than 20 ultra fine particles/m³.
- Class M 1.5 (at 0.3 µm), U(2000) describes air with not more than 106 particles/m³ of 0.3 µm and larger and not more than 2000 ultra fine particles/m³.

Number of sample locations required

For *unidirectional* airflow the number of sample locations required for verification of class shall be the lesser of the two following alternatives a and b, where area is the entrance plane and M the metric class.

- Area (m²) / 2.32
- Area (m²) * 64 / (10^M)^{0.5}

For *nonunidirectional* airflow the minimum number of sample locations should be as alternative b) above, but the area is the floor area.

In any case no fewer than two locations should be sampled and at least five samples shall be taken in each zone (more than one sample could be taken at the same location).

Sample volume and time

The minimum sample volume and sample time will be calculated in order to have 20 counts at the class limit.

$$\text{volume} = 20/\text{class limit concentration}$$

$$\text{time} = \text{volume}/\text{sample flow}$$

For example:

Class M 2 (at 0.3 µm) has 309 particles/m³ as class limit

$$\text{volume} = 20/309 = 0.0647 \text{ m}^3 = 64.7 \text{ litre}$$

For a particle counter with a sample flow of 28.3 litre/minute (1 cubic foot/minute) the minimum sample time will then be 64.7/28.3 = 2.3 minutes

It is important to have high sample flow to reduce time when verifying high cleanliness.

Acceptance criteria

The air shall have met the acceptance criteria for a cleanliness class when the averages of the concentrations measured at each locations fall at or below the class limit or the U descriptor.

If the total number of locations is less than ten, the mean of the averages must fall at or below the class limit with 95 % UCI. (Upper Confidence limit) described in the standard.

Others

The 209E standard also includes the following appendixes

- Counting and sizing airborne particles using optical Microscopy
- Operation of Discrete-Particle Counter
- Isokinetic and unisokinetic sampling
- Method for measuring the concentration of ultrafine particles
- Rationale for the statistical rules used in Fed Std 209E
- Sequential sampling
- sources of supplemental information

OLD US FED STD-209D, 1988

The classification system was based on the number of particles 0.5 μm per cubic foot of air and the following table gives the class limits in particles per cubic foot of size, equal to or greater than particle sizes shown.

Class	Max. number of particles/cft				
	0.1 μm	0.2 μm	0.3 μm	0.5 μm	5 μm
1	35	7.5	3	1	NA
10	350	75	30	10	NA
100	NA	750	300	100	NA
1 000	NA	NA	NA	1 000	7
10 000	NA	NA	NA	10 000	70
100 000	NA	NA	NA	100 000	700

NA = not applicable

FRANCE AFNOR NFX 44-101, 1981

In France the ASPEC Communication 7202 classifies three room classes 4000, 400 000 and 4 000 000 as follows:

Class	Max. number of particles/m ³	
	0.5 μm	5 μm
4 000	4 000	25
400 000	400 000	2 500
4 000 000	4 000 000	25 000

The room shall be at rest when determining the room class.

The French version bases the classes on the number of particles 0.5 μm per m³ of air. The standard has almost followed the distribution curves in Fed Std 209 but changed the number of particles to more uniform metric figures. Class 100 which is 3.5 particles/l or 3500 particles/m³ is supposed to be class 4000 according to AFNOR.

GERMANY VDI 2083, 1990

In Germany the VDI 2083 follows the French change to more uniform figures and to the number of particles per m³ of air. But the system is based on 1 μm particles and the 10 exponent of the concentration. The classes 2, 3, 4 ... are close to the distribution curves in Fed Std 209 and the French system.

Class	Particles/m ³	
	1 μm	0.5 μm
0	10 ⁰	4x10 ⁰
1	10 ¹	4x10 ¹
2	10 ²	4x10 ²
3	10 ³	4x10 ³
4	10 ⁴	4x10 ⁴
5	10 ⁵	4x10 ⁵
6	10 ⁶	4x10 ⁶

The class of the room shall be measured during working conditions.

GGMP PIC/EEC 1989

The organisations for pharmacy make international standards. (Guides to Good Manufacturing Practice). The Pharmaceutical Inspection and EEC define in GGMP four different classes A, B, C and D. They are approximately equivalent to Class 100 (A and B) Class 10000 (C) and Class 100 000 (D).

JAPAN JACA No 24 - 1989

The Japanese classification is similar to the German VDI system, but instead of using the number of particles 1.0 μm it uses the 0.1 μm particle size. The 10-exponent of the count of particles 0.1 μm per m³ gives the class of the room.

Class	Particles/m ³ 0.1 μm
0	10 ⁰
1	10 ¹
2	10 ²
3	10 ³
4	10 ⁴
5	10 ⁵
6	10 ⁶
7	10 ⁷
8	10 ⁸

ENGLAND BS 5295 - 1989

To avoid confusion with the old system the new BS 5295 has a letter system, C, D, E ..., instead of the old number system and the number of classes is also changed from 4 to 10.

The classification is based on the number of particles 0.5 μm per m³ of air and the class limits are close to the Fed Std 209.

class	Maximum number of particles/m ³				
	0.3 μm	0.5 μm	5 μm	10 μm	25 μm
C	100	35	0	NS	NS
D	1 000	350	0	NS	NS
E	10 000	3 500	0	NS	NS
F	NS	3 500	0	NS	NS
G	100 000	35 000	200	0	NS
H	NS	35 000	200	0	NS
J	NS	350 000	2 000	450	0
K	NS	3 500 000	20 000	4 500	500
L	NS	NS	200 000	45 000	5000
M	NS	NS	NS	450 000	50 000

NS = not specified

Designation of the installation shall include the class followed by one of the three states of operation as: "as built", "manned" or "unmanned".

SUMMARY - CLASSIFICATION

The class limits of particle concentrations are defined for class purposes only and do not necessarily represent the actual situation.

ISO 14644 will replace all national standards in a couple of years.

An approximate comparison of major clean room classes, comparing the 0.5 µm particle size, is given in Table 8.

Table 8. An approximate comparison of major clean room classes comparing 0.5 µm particle size. Note that the different classifications use different concentrations, particle sizes and different slopes of the curve as base for respective classification.

Particles per m ³ > 0.5 µm	ISO class 14644-1 1999	US 209E 1992	US 209D 1988	EEC GGMP 1989	France AFNOR 1981	Germany VDI 2083 1990	Britain BS 5295 1989	Japan JACA 1989
1								
3.5	2					0		2
10.0		M 1						
35.3	3	M 1.5	1			1		3
100		M 2						
353	4	M 2.5	10			2		4
1 000		M 3						
3 530	5	M 3.5	100	A + B	4 000	3	E or F	5
10 000		M 4						
35 300	6	M 4.5	1 000			4	G or H	6
100 000		M 5						
353 000	7	M 5.5	10 000	C	400 000	5	J	7
1 000 000		M 6						
3 530 000	8	M 6.5	100 000	D	4 000 000	6	K	8
10 000 000		M7						
							(L)	
							(M)	

TESTING OF INSTALLATIONS

Absolute filters should be manufactured to a very high quality with every filter being tested and checked before delivery. However in some cases the filters may be damaged during transport or when being installed.

It is therefore important to check, the filter itself, the sealing between filters and frames, and the whole installation. The frame system is probably the most critical part in a new installation.

Such an "in situ" test does not require the high penetrating test aerosol as used in the manufacturers' quality test. A hole or leak will pass particles of rather large dimensions.

Installed filters are therefore tested regarding the total or overall efficiency of the filter system or/and if there are any unacceptable leaks.

Many standards have been developed and some of the most usual are:

Standard	Test-aerosol	Test	Equipment
IES-RP-CC-002-86	DOP	L	Photometer
IES-RP-CC006.2	DOP	L+OE	Photometer
IES-RP-CC006.2	DOP	L	Photometer
IES-RP-CC006.2	Natural	L	Counter
BS 5295 Part 1 C	(DOP)	L	Photometer
BS 5276	DOP/NaCl	L+OE	Photometer
Eurovent 4/8	DOP	L+OE	Photometer
ANSI N510	DOP	OL	Photometer
NE F-3-41	DOP	OE	Counter
ASTM F 91-70	CNC	L	Nuclei " "
NSF 49	DOP	L	Photometer

L = Leak test OE = Overall Efficiency test

Introduction of the aerosol may contaminate the filter, the clean room or equipment. The use and type of test aerosol has to be agreed on.

Most standards use DOP (dioctylphthalate) particles generated upstream of the filter system. The aerosol is pneumatically generated with an approximate mean diameter of 0.65 μm .

The polydispersed DOP aerosol used for in place leak testing must not be confused with 0.3 μm monodispersed DOP aerosol used for individual testing of Absolute filters during manufacturing.

The aerosol produced by a Laskin nozzle has the following light scattering mean droplet size distribution

99 % less than	3.0 μm
50 % less than	0.7 μm
10 % less than	0.4 μm

The BS 5295 don't specify type of test aerosol, but the distribution shall be

75 % less than	1 μm
50 % less than	0.7 μm and
20 % less than	0.5 μm ,

which is close to the DOP distribution.

The overall efficiency is normally determined by measuring the DOP concentration upstream and downstream of the filter by a photometer.

The only standard that describes DOP and particle counters is NE F-3-41 when testing two Absolute filters in series. The normal photometer can be used for penetrating factors of 10^1 to 10^3 and this is not enough for filters in series.

LEAKS

The leak test is made by scanning the whole filter and filter system downstream of the filter. An unacceptable leak varies with standard and filter quality.

According to British Standard BS 5276: the maximum permitted concentration for Cleanliness classes C, D, E and F is 0.001% of upstream concentration. For other classes where high efficiency filters are used is the maximum permitted concentration 0.01%.

IES-RP-CC006.2. (testing Clean rooms) specifies a leak when photometer reading in any place is greater than 0.01 % of the upstream reading.

Installation leak tests can also be done with particle counters as described in IES-RP-CC006.2 if the buyer and seller agree on specific test conditions, challenge aerosol, distribution and concentration and the definition of a leak. The standard explains those problems and the statistical approach of testing.

DOP TEST AEROSOL

DOP, dioctylphthalate, also known as DEHP (di-2-ethylhexyl phthalate) is the most well known test aerosol and has been used in many years for testing filters in production and "in situ".

DEHS-TEST AEROSOL

DEHS or DOS or DES has replaced DOP in many cases. The particles are generated in the same way.

DEHS is the same as

DES, Di(2-ethylhexyl) Sebacate or

Bis(2-ethylhexyl) Sebacate, $C_{26}H_{50}O_4$ or

DOS (Dioctyl Sebacate).

EMERY 3004 TEST AEROSOL

The possibility that DOP may be carcinogenic under certain conditions has introduced other test aerosols as DEHS and Emery 3004.

Emery 3004 which is a synthetic hydrocarbon used as synthetic lubricant, has replaced DOP in some applications. The Emery 3004

- performs as well as DOP without modification of existing test equipment.
- inexpensive
- noncorrosive and clean to work with
- non-mutagen and safe to work with

Other aerosols to be used are

- Mineral oil
- Oleic acid
- PSL, polystyrene latex spheres.

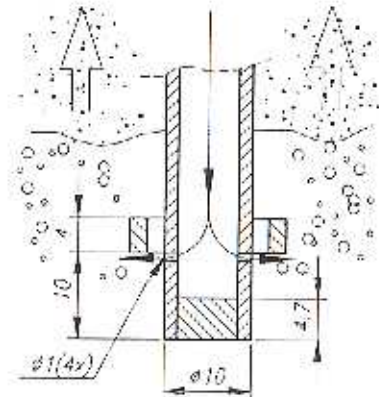

Figure 17. Drawing of a Laskin nozzle. The aerosol is generated by blowing compressed air through the nozzle into the DEHS liquid.

PARTICLE COUNTERS

The classical particle counters for Clean Rooms (Royco and Climet) measured and counted particles down to $0.5\ \mu\text{m}$. The sample flow was one cubic foot per minute (1 CFM = 28.4 l/minute).

The conventional standards for classification and testing of Clean Rooms were based on such equipment. The high sample flow (1 CFM) made them suitable for particle leak scanning of filters and filter installations.

Normally there is a relationship between minimum measurable particle size and sample flow. By reducing the sample flow it was possible to measure down to the particle size $0.3\ \mu\text{m}$ with similar instruments. The developments and improvements of the optical part of the instruments led to particle counters reading down to $0.3\ \mu\text{m}$ with a sample flow of 1 cfm. By measuring down to $0.3\ \mu\text{m}$ instead of $0.5\ \mu\text{m}$ more particles could be found in the air. With higher demands of cleanliness the existing standards could be used by referring to size $0.3\ \mu\text{m}$ instead of the conventional $0.5\ \mu\text{m}$ size.

Laser light and modern electronics made it possible to count particles down to about $0.1\ \mu\text{m}$ but at the expense of sample flow. A typical sample flow of a laser counter could be $5\ \text{cm}^3/\text{s}$ or 0.01 cfm. This is only 1/100 of the flow for conventional particle counters as used in Clean Rooms. This low sample flow has a particular importance for the accuracy when classifying Clean Rooms. The low sample flow makes it difficult to scan filters in the installations.

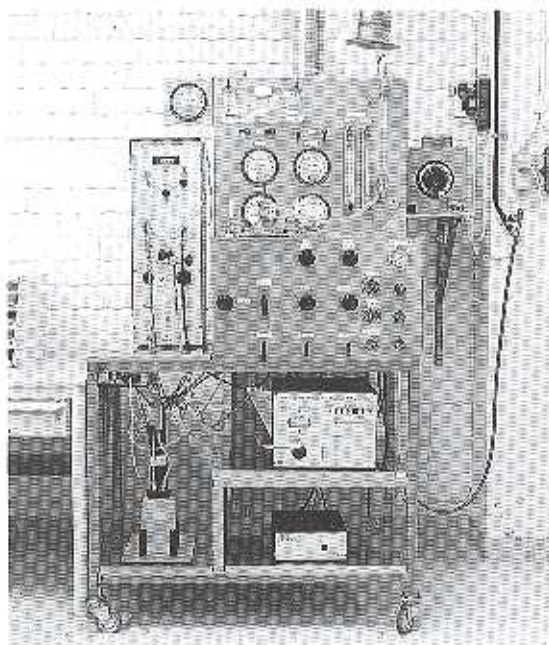

Figure 18. CNC media test.

Today however the highest sensitivity and flow rate capacity laser counters can measure down to $0.1\ \mu\text{m}$ at an airflow of 1 cfm. This is achieved by using several "pulse photodetector high analysis" for particle size determination. Each detection covers a part of the laser beam.

Other types of particle counter are the CNC counters (Condensation Nucleus Counters). They count all particles in the air independent of size, even particles much smaller than $0.1\ \mu\text{m}$. In the CNC alcohol is condensed on particles that then grow to about $12\ \mu\text{m}$ in size and become easy to count.

Together with a Diffusion Battery (DB) or an Electrostatic Classifier (EC) the CNC can be used for counting the number and size of particles down to $0.01\ \mu\text{m}$. With the EC placed before the CNC, the particles can successively be separated into different particle sizes. The CNC then counts the numbers of particles in each size. It's a time consuming test compared with systems based on optical particle counters.

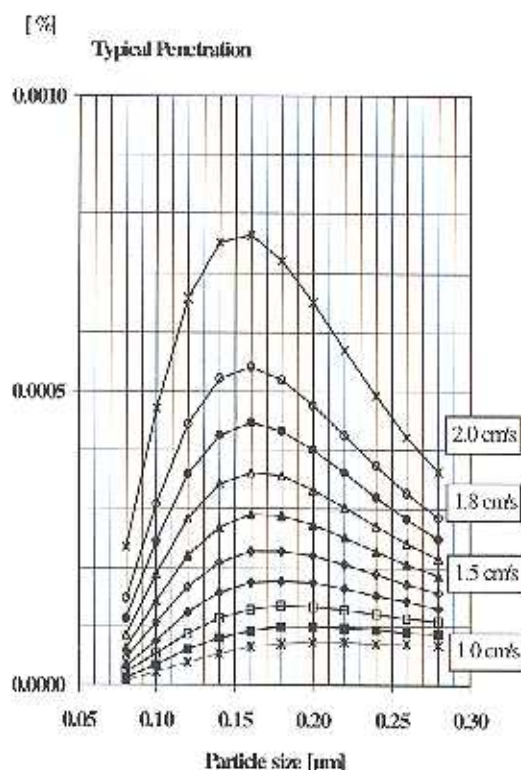

Figure 19. The results of an absolute filter media at a range of sample flows. The penetration varies with particle size and media velocity.

As well as the minimum measurable particle size or type of equipment there are a few things that should be noted in all particle tests, such as the type of aerosol, number of particles and the noise level of the instrument (the level where the internal electrical impulses cannot be separated from particles impulses).

TYPE OF AEROSOL

All particle counters are calibrated against some known particle. Usually these are latex particles that can be obtained in very exact sizes. One particle that gives the same refraction as $1\ \mu\text{m}$ latex particle will then be registered as $1\ \mu\text{m}$ particle. The difference in refractive index and the irregularity of particles will of course influence of the size designation.

NUMBER OF PARTICLES

To obtain reliable values requires that the number of particles counted are not too small.

Counting of particles normally follows the Poisson distribution law. If N particles are measured the standard deviation is \sqrt{N} and the error for a probability level of 95 % is two times that standard deviation.

If 100 particles are registered by a particle counter the probable error due to the counting is $2(10^{1/2}) = 20$ or 100 ± 20 particles or in this case $\pm 20\%$. While just 16

measured particles will give a statistically misleading reading of ± 8 particles or $\pm 50\%$.

The number of measured particles must be great enough to give an acceptable error, which should be pointed out by room classification. On the other hand the concentration cannot be too high. There must be a statistical small probability that two or more particles can be in the light beam at the same time.

NOISE LEVEL

(Internal electric impulses in the instrument)

The lowest particle size depends on sample flow and geometric design of the light beam and chamber. Lower flow - smaller size.

It is important to know that the counters are working very close to the noise level of the instrument and that internal electrical impulses can be registered as particles in the lowest level. The result close to the limit could be influenced by particles below the minimum measurable size.

Usually the measurements are made within pre-set sizes and intervals. With a multi channel analyser the interval can be very narrow, but this will complicate the precision, as the number of particles can be too small to give a statistically satisfactory result.

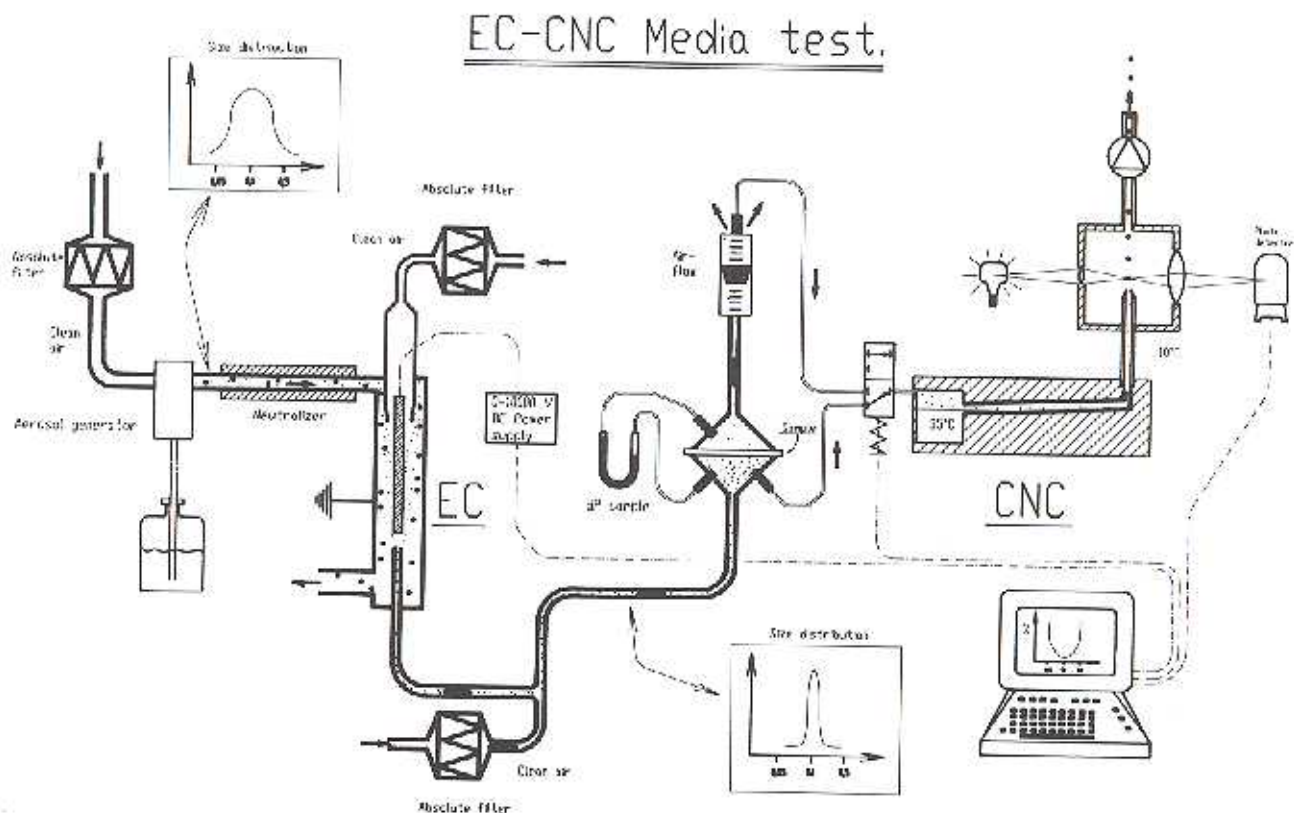

Figure 20. The principle of the CNC test method for measuring the Most Penetrating Particle Size for filter media.

SYSTEM COMPONENTS

Filters are a necessity for highly clean conditions. But a filter is just one component in a system. The final result depends in most cases more on the cleanliness of the raw material and its handling, the protection of the product and the air distribution. The most important thing to control is the dust generated from those who work in the room and from the installed machinery.

The filter is normally the easiest part in this equation. Unfortunately many think that good filters are the solution to the problem. This is not necessary true, but if you have selected the best possible filter quality you can at least exclude one possible error when problems are showing up.

The cleanliness after a filter does not say anything about the cleanliness in the room or in the process. Conversely, a certain claim of cleanliness class at the process does not say anything about which filter quality should be used. A certain minimum quality is needed, depending on other components in the plant.

The first step is to have clean air to start with. Before we see which cleanliness class could be achieved with different filter qualities in different applications we should analyse some of the facts that influence the environment. Some of these are shown in the diagrams and in "BASIC DATA FOR CLEAN ROOMS" later in this publication.

FILTER

Filters are in different stages in the system and the main consideration is to know the efficiency for different particle sizes. The efficiency for 0.1 μm particles varies for example from approximately 15 % for HI-FLO 65 to 99.99995 % for SUPER GOLD SEAL filter. Efficiency for other filters and particle sizes can be seen in the BASIC DATA and diagrams.

OUTDOOR AIR

Every air conditioning system is based on outdoor air and one has to know its contamination level, which of course varies a great deal with the place and the time.

In the "BASIC DATA tables" there is an example of clean air where the number of particles larger than 0.1 μm is 5×10^8 per m^3 of air. But in dirty outdoor air the number of particles larger than 0.10 μm can be as much as 10^{10} particles per m^3 .

INTERNAL DUST GENERATION

The most difficult problem when designing a clean room is to calculate the internal dust generation and its influence on the process. The human being is normally the most dominating factor, but also the process itself can in many cases generate particles.

Tests made with a laser particle counter show that a human being with working clothes engaged in extreme movement, could generate up to 10^6 particles larger than 0.1 μm per second. The generation of particles larger than 0.3 μm is 4×10^5 and larger than 0.5 μm about 2×10^5 particles per second.

The number of particles generated varies greatly depending on activity and type of clothing. It is possible to reduce the above maximum number of particles by 10 to 100 times with suitable clothes and routines. The number of particles generated by machines has to be given by the manufactures in each case.

CHOICE OF FILTER - CALCULATIONS

Which cleanliness classes respective could be obtained depends on the different components.

The following examples show, together with diagrams for laminar and non laminar systems, how cleanliness classes can be calculated under different conditions.

The formulas used are approximate. More details could be found in Camfil "Ventilation System Design"-book. The calculations could be made with help of the computer program "CleanRoom Calculation".

UNIDIRECTIONAL FLOW ROOM WITH 100 % OUTDOOR AIR

Which cleanliness class regarding 0.1 μm particles could be achieved in a room with HI-FLO 85 as prefilter and a GOLDSEAL clean room filter as final filter?

Suppose that the installation is in a very dirty area and that 100 % outdoor air has to be used.

From the diagrams or basic data tables we can see that a dirty air could have a concentration of 10^{10} particles/ m^3 larger than 0.1 μm . HI-FLO 85 have 50 % efficiency of these particles, while the GOLDSEAL filter takes 99.9998 % of the 0.1 μm particles.

The HI-FLO 85 will reduce the concentration by 50 % to 5×10^9 particles/m³. The GOLDSEAL filter takes 99.9998 % of the remaining particles and the concentration downstream the filter will be $0.000002(5 \times 10^9) = 10^4$ or 10 000 particles/m³.

The class according to Fed Std 209E could approximately be calculated by the equation

$$\text{Particles/m}^3 = 10^M(0.5/d)^{2.2}$$

or in our case

$$10\ 000 = 10^M(0.5/0.1)^{2.2}$$

which gives

$$M = 2.46 \text{ (at } 0.1 \mu\text{m)}$$

We can see in 209E table that we are close to cleanliness class M 2.5, where the number of particles shall not be more than 12 400 particles/m³.

10 000 particles/m³ larger than 0.1 μm corresponds to ISO Class 4.

UNIDIRECTIONAL FLOW ROOM WITH 100 % RECIRCULATED AIR

Which 0.1 μm cleanliness class could be achieved in a room with 100 % recirculated air and one person per 10 m² as the only dust generator?

The "laminar" velocity of 0.45 m/s gives for 10 m² an air flow of 4.5 m³/s per person. If we assume maximum number of particles from one person then the dust generation will be 10⁶ particles/sec and the concentration upstream of the filter could be calculated according to the formula (see diagram later)

$$C_{up} = S/Q$$

or

$$C_{up} = 10^6/4.5 = 2.2 \times 10^5 \text{ particles/m}^3$$

Downstream of a MICRUTAIN filter with 98 % efficiency there will be $0.02(2.2 \times 10^5) = 4400$ particles/m³ equal to or larger than 0.1 μm. This filter will give higher concentration than class M 2 (at 0.1 μm), which is maximum 3 500 particles/m³.

UNIDIRECTIONAL FLOW ROOM WITH RECIRCULATED AIR

Suppose 80 % recirculated air ($X=0.8$) and dirty outdoor air ($C_{out}=10^{10}$ particles/m³ >0.1 μm) and the dust generation from one person is as much as 10⁶ particles/s.

One person per 10 m² gives the "laminar" air flow of 4.5 m³/s

With HI-FLO 85 as a pre-filter ($\eta_p=0.5$) the concentration upstream of the final filter will be (see formula in the diagram in the end)

$$C_{up} = X S/Q + (1-X)(1-\eta_p) C_{out}$$

or

$$\begin{aligned} C_{up} &= 0.8 \times 10^6/4.5 + (1-0.8)(1-0.5)10^{10} \\ &= 1.78 \times 10^5 + 10^9 \\ &= \text{ca } 10^9 \text{ (particles/m}^3 \text{ >0.1 } \mu\text{m)} \end{aligned}$$

The influence of the internal dust generation is only 1.78×10^5 compared with 10^9 particles/m³ from outdoor air. The internal dust generation will not affect the level upstream of the final filter very much. The concentration downstream a Goldseal final filter with 99.9998 % of 0.1 μm particles filter is $(2 \times 10^{-6}) \times 10^9 = 2000$ particles/m³ and the cleanliness class could be estimated

$$M = \log 2000 - 2.2 \log(0.5/0.1) = 1.76$$

The cleanliness class is better than the M 2 (at 0.1 μm).

If we make the same calculation for ISO classification we get the following equation based on 0.1 μm particles

$$2000 = 10^N \log(0.1/0.1)^{2.08}$$

$$N = 3.3$$

The room will meet the ISO Class 3.3.

NONUNIDIRECTIONAL AIRFLOW SYSTEM

Suppose:

Dirty outdoor air $C_{out}=10^{10}$ particles/m³ >0.1 μm.

1 person/10 m² generating 10⁶ particles/s >0.1 μm.

An air change of 30 times/h and a room height of 3 m gives 0.25 m³/s per person.

80 % ($X=0.8$) recirculated air

HI-FLO 85 as prefilter ($\eta_p=0.5$).

Absolute filter as final filter $\eta_f=0.99998$

The cleanliness class or concentration in room could approximately be calculated with the following formula (see diagram)

$$C = S/Q + (1-X)(1-\eta_p)(1-\eta_f)C_{out}$$

or

$$\begin{aligned} C &= 10^6/0.25 + (1-0.8)(1-0.5)(1-0.99998) \cdot 10^{10} \\ C &= 4 \times 10^6 + 2 \times 10^4 \\ C &= 4\ 020\ 000 \text{ (particles/m}^3 \text{ >0.1 } \mu\text{m)} \end{aligned}$$

The class will approximately be

$$M = \log(4\ 020\ 000) - 2.2 \log(0.5/0.1) = 5.06$$

This is too high concentration to be covered in the standard classes according to 209E.

A better filter has no influence on the cleanliness level, in this example. The only way to decrease concentration is to reduce the internal dust generation with better clothes, covers, higher airflows or find a better technical solution, unidirectional airflow for instance.

The same calculation made for 0.5 μm particles gives

Hi-Flo 85 $\eta_p=0.7$
 Absolute $\eta_p=0.999999$
 $S=2 \times 10^5$ particles/s > 0.5 μm
 $C_{out}=3 \times 10^7$ particles/m³ > 0.5 μm

$$C = 2 \times 10^5 / 0.25 + (1 - 0.8)(1 - 0.7)(1 - 0.999999) \cdot 3 \times 10^7$$

$$C = 8 \times 10^5 + 2 = 800\,002 \text{ (particles/m}^3\text{)}$$

The class could be estimated

$$M = \log(800\,002) - 2.2 \log(0.5/0.5)$$

$$M = 5.9 \text{ (at } 0.5 \text{ } \mu\text{m)}$$

We will meet class M 6 (at 0.5 μm) according to 209E.

The ISO Class could be calculated in the similar way

$$N = \log(800\,002) - 2.08 \log(0.1/0.5)$$

which gives

$$N = 7.35$$

And the environment will meet ISO Class 7.4

Again a better filter has no influence on the cleanliness level in this case. The only way is to reduce the dust generation or increase air change rate.

The same calculation for 0.5 μm particle and a Microtain filter with the efficiency $\eta_p=0.99$ gives the following calculation

$$C = 2 \times 10^5 / 0.25 + (1 - 0.8)(1 - 0.7)(1 - 0.99) \cdot 3 \times 10^7$$

$$= 800\,000 + 18\,000 = 818\,000 \text{ (particles/m}^3\text{)}$$

The class will be M 5.91 (at 0.5 μm). A very small change.

GOOD LUCK
with further calculations!

Diagrams/Tables - enclosed

1. Efficiency for filters
2. Outdoor air
3. Human dust generation
4. ISO 14644-1 Air Cleanliness classes
5. Fed Std 209E Air Cleanliness classes
6. Basic Data- Clean room tables
7. Laminar Air Flow System, Unidirectional
8. Absolute filter installations, Nonunidirectional
9. Clean benches installations

DIAGRAM 1.
Penetration vs. particle size for Camfil filters

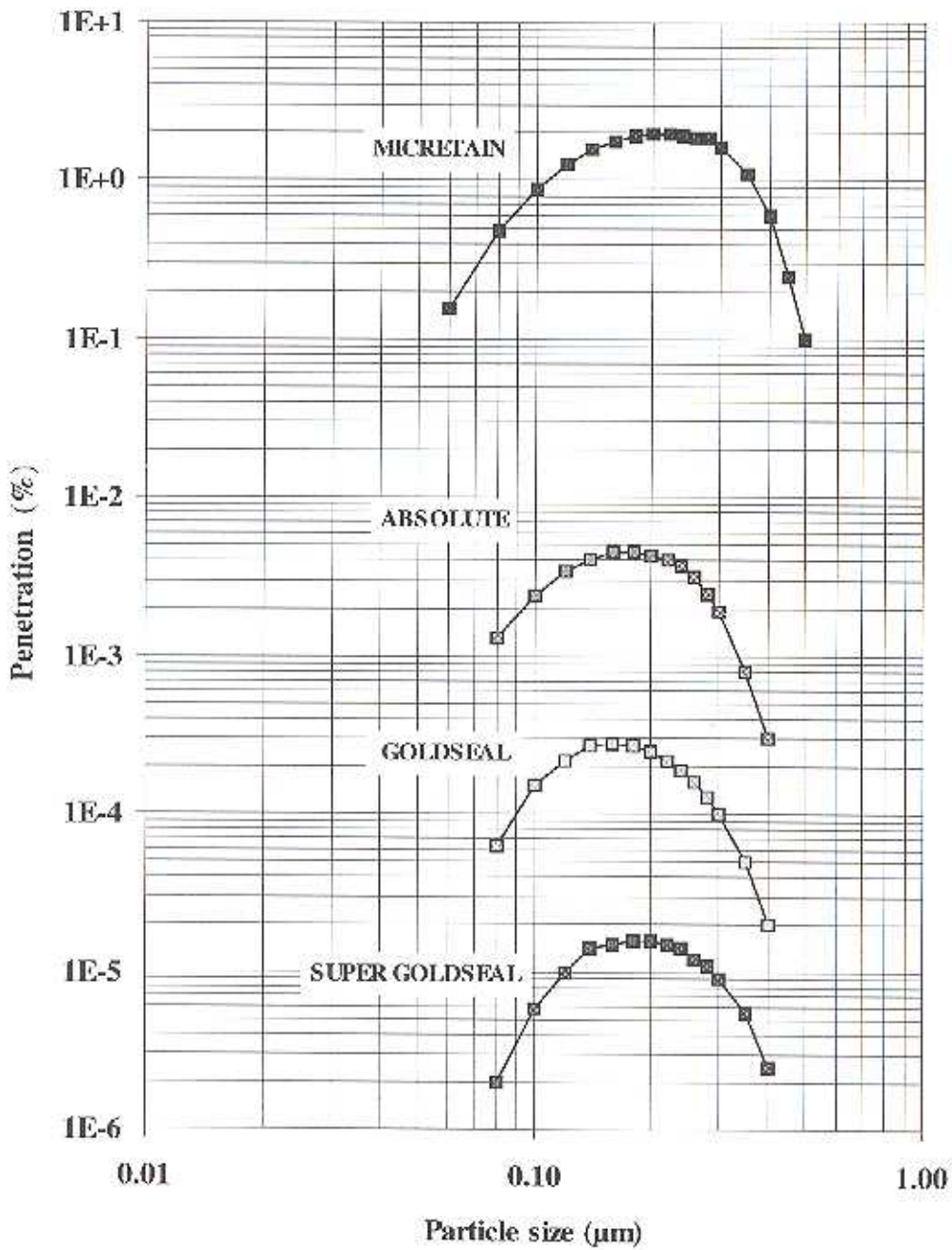
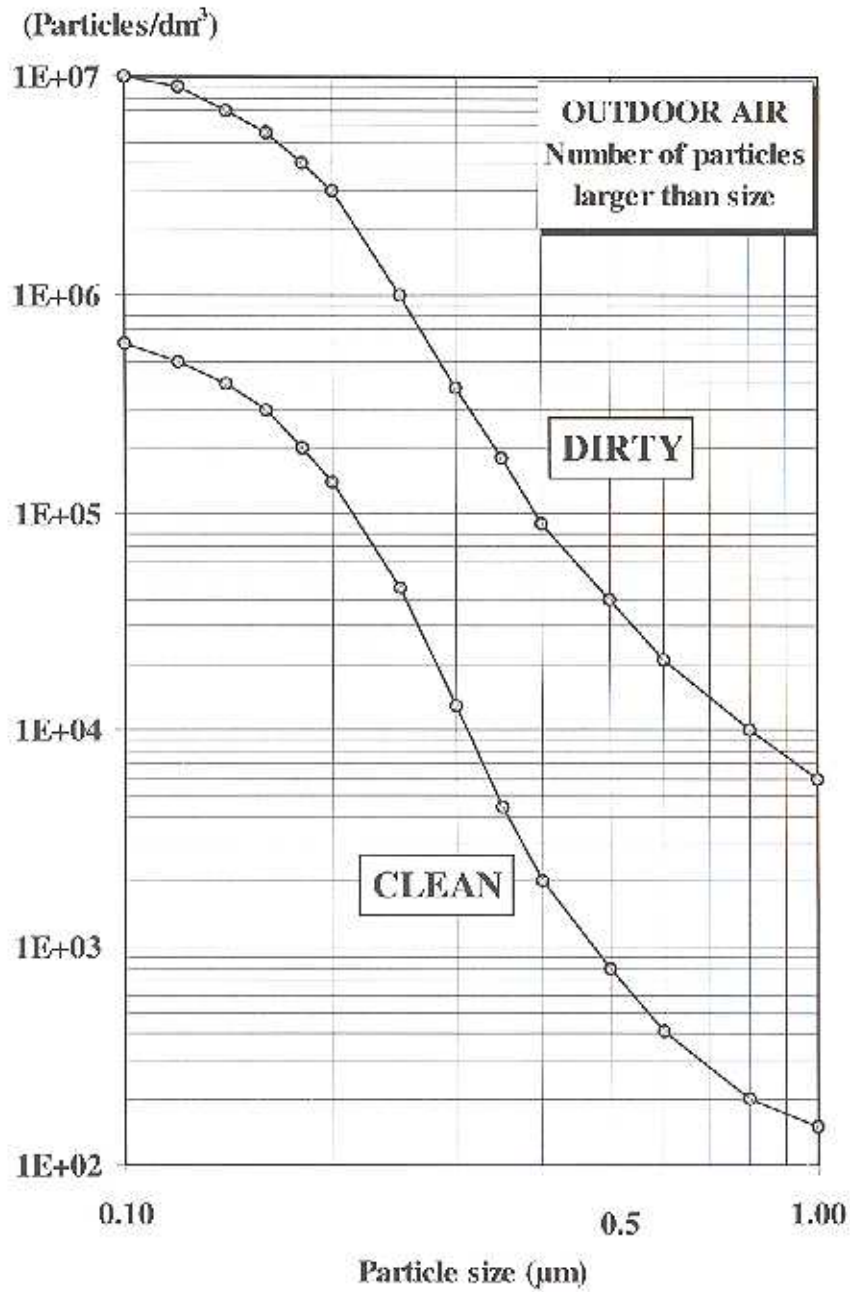

DIAGRAM 2.
OUTDOOR AIR



**DIAGRAM 3.
HUMAN DUST GENERATION**

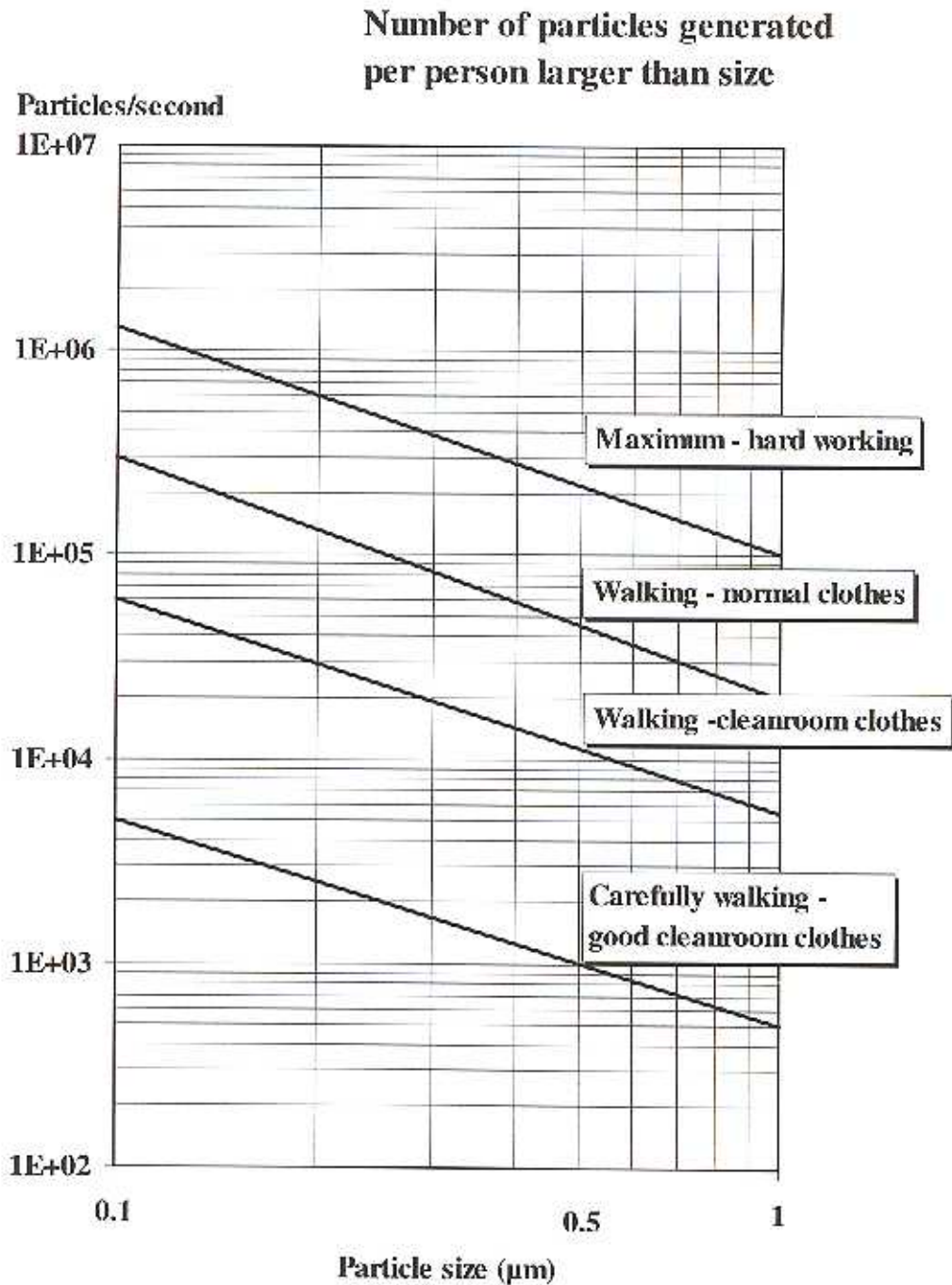

DIAGRAM 4.
CLASSIFICATION ACCORDING TO ISO 14644-1

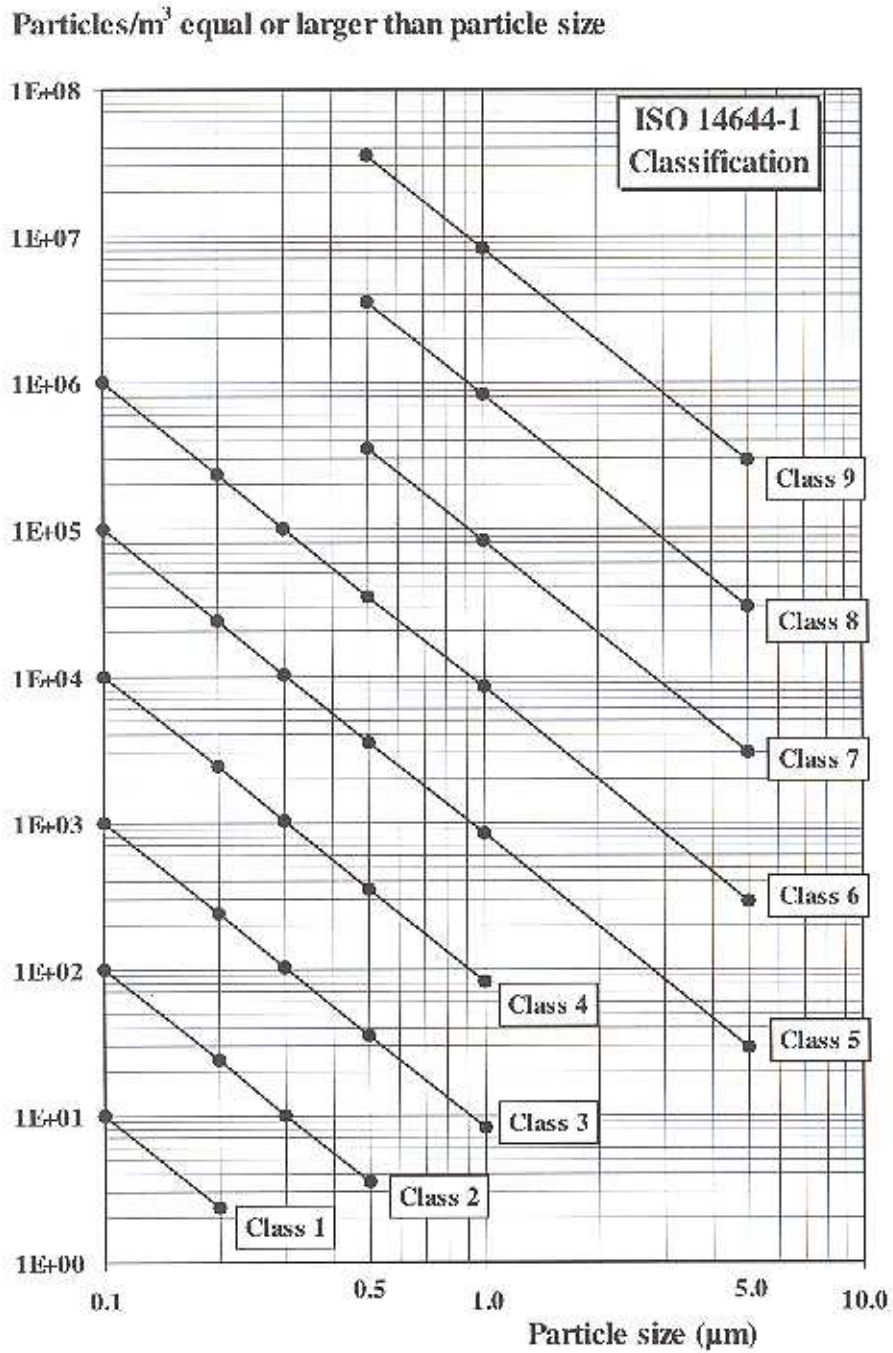

DIAGRAM 5.
CLASSIFICATION ACCORDING TO Fed Std 209E

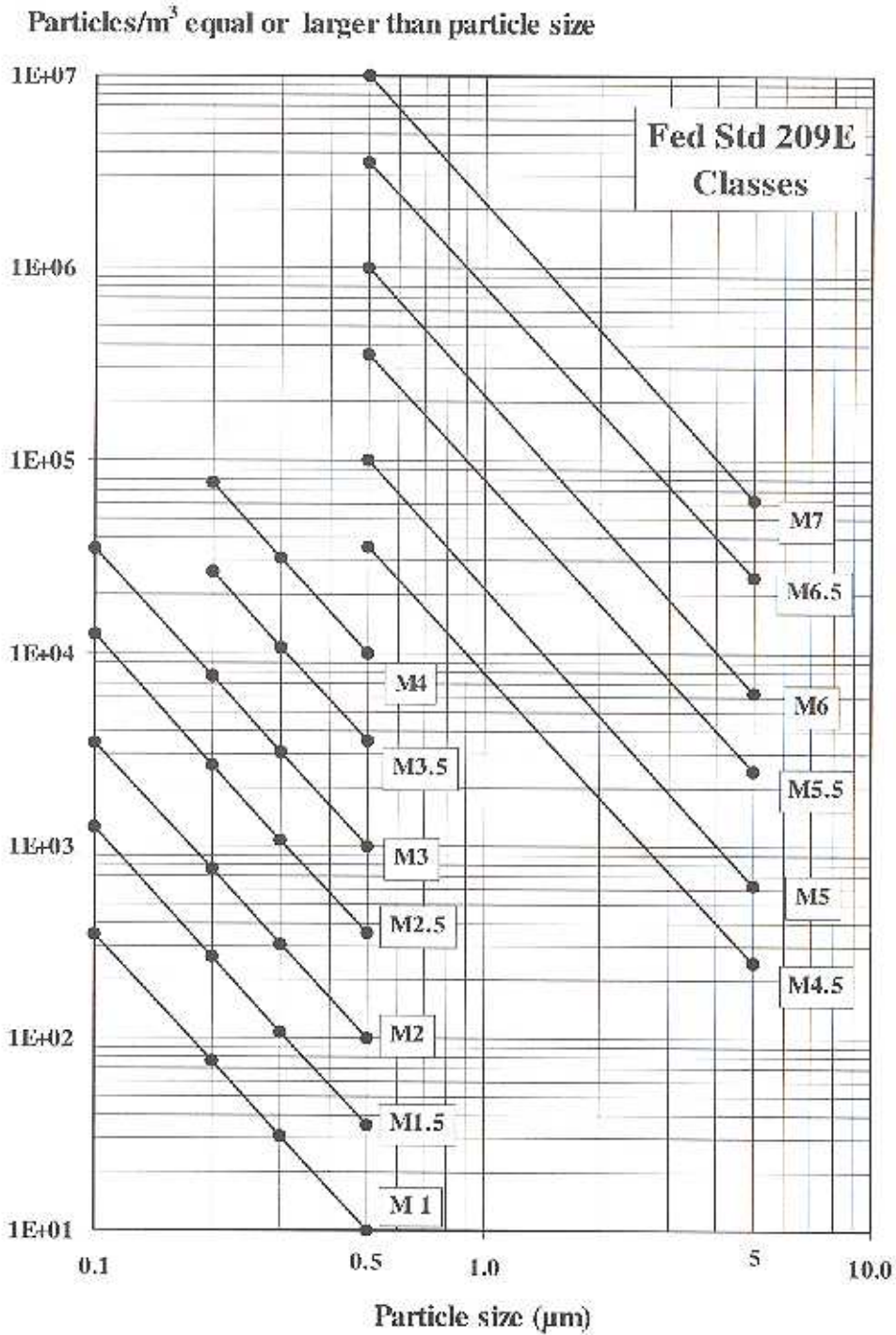

DIAGRAM 6. SUMMARY - BASIC DATA

OUTDOOR AIR

Number of particles larger than size

Size μm	Particles/ m^3	
	dirty	clean
0.1	1×10^{10}	5×10^8
0.3	3×10^8	2×10^7
0.5	3×10^7	1×10^6

HUMAN DUST GENERATION

Number of particles/second larger than size per person

Size μm	Walking		carefully
	maximum	clean room clothes	walking clean room cloths
0.1	1×10^6	5×10^4	5×10^3
0.3	4×10^5	2×10^4	2×10^3
0.5	2×10^5	1×10^4	1×10^3

FILTER EFFICIENCY - PENETRATION (examples of Clean Room Filters)

Filter	Efficiency %				Penetration %			
	MPPS	0.1 μm	0.3 μm	0.5 μm	MPPS	0.1 μm	0.3 μm	0.5 μm
SUPER GOLDFEAL	99.99998	99.999995	99.99999	(100)	2×10^{-5}	5×10^{-6}	1×10^{-5}	(0)
GOLD SEAL	99.9997	99.9998	99.9999	(100)	3×10^{-4}	2×10^{-4}	1×10^{-4}	(0)
ABSOLUTE	99.995	99.997	99.998	99.9999	5×10^{-3}	3×10^{-3}	2×10^{-3}	1×10^{-4}
MICRETAIN	98	99	98.5	99	2	1	1.5	1
HI-FLO 95	-	70	80	90	-	30	20	10
HI-FLO 85	-	50	60	70	-	50	50	30
HI-FLO 65	-	15	20	25	-	85	80	75

CLEANLINESS CLASSES ISO 14644-1

Class	Max. concentration (particles/ m^3) for particles equal to and larger than the considered sizes shown below					
	0.1 μm	0.2 μm	0.3 μm	0.5 μm	1 μm	5 μm
ISO Class 1	10	2				
ISO Class 2	100	24	10	4		
ISO Class 3	1 000	237	102	35	8	
ISO Class 4	10 000	2 370	1 020	352	83	
ISO Class 5	100 000	23 700	10 200	3 520	832	29
ISO Class 6	1 000 000	237 000	102 000	35 200	8 320	293
ISO Class 7				352 000	83 200	2 930
ISO Class 8				3 520 000	832 000	29 300
ISO Class 9				35 200 000	8 320 000	293 000

CLEANLINESS CLASSES FED STD 209E

209E Class	Max. particles/ m^3				
	0.1 μm	0.2 μm	0.3 μm	0.5 μm	5 μm
M 1	350	75.7	30.9	10.0	-
M 1.5	1 240	265	106	35.3	-
M 2	3 500	757	309	100	-
M 2.5	12 400	2 650	1 060	353	-
M 3	35 000	7 570	3 090	1 000	-
M 3.5	-	26 500	10 600	3 530	-
M 4	-	75 700	30 900	10 000	-
M 4.5	-	-	-	35 300	247
M 5	-	-	-	100 000	618
M 5.5	-	-	-	353 000	2 470
M 6	-	-	-	1 000 000	6 180
M 6.5	-	-	-	3 530 000	24 700
M 7	-	-	-	10 000 000	61 800

DIAGRAM 7.
UNIDIRECTIONAL FLOW SYSTEM - Cleanliness calculation

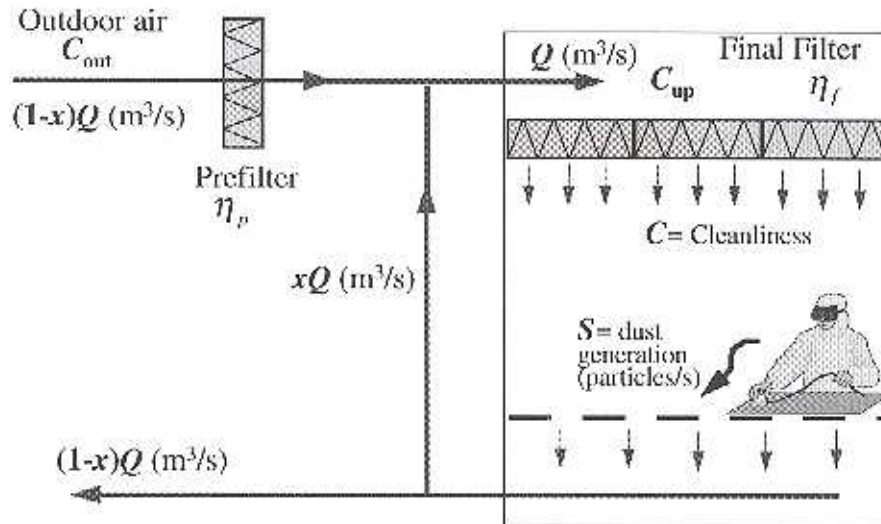

Concentration upstream FINAL FILTERS

$$C_{up} = xS/Q + (1-x)(1-\eta_p)C_{out}$$

Cleanliness class downstream FINAL FILTERS

$$C = [xS/Q + (1-x)(1-\eta_p)C_{out}](1-\eta_f)$$

Special Case A: 100 % outdoor air and no recirculation of air (x=0)

Concentration upstream final filter

$$C_{up} = (1-\eta_p)C_{out}$$

Cleanliness class in room downstream final filter

$$C = (1-\eta_p)C_{out}(1-\eta_f)$$

Special Case B: 100 % recirculated air (x=1) and no outdoor air

Concentration upstream final filter

$$C_{up} = S/Q$$

Cleanliness class in room downstream final filter

$$C = S/Q (1-\eta_f)$$

DIAGRAM 8.
NONUNIDIRECTIONAL FLOW SYSTEM - Cleanliness calculation

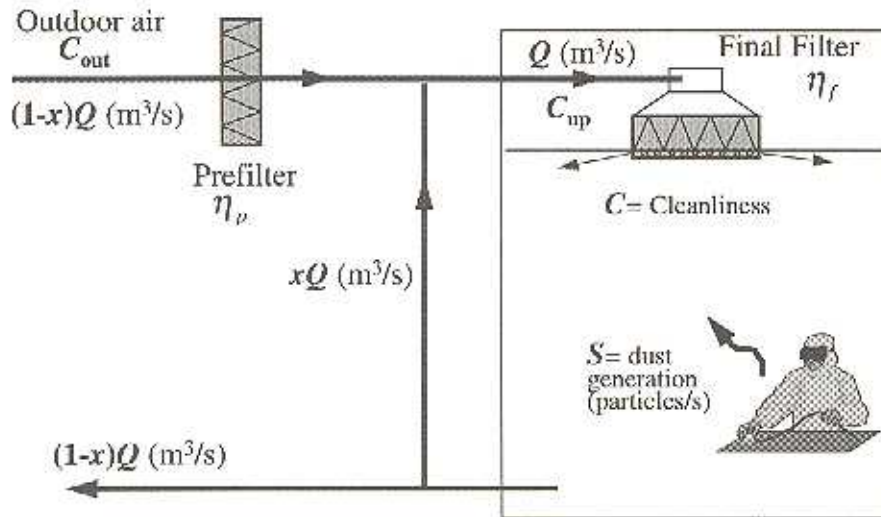

Cleanliness class in room

$$C = S/Q + (1-x)(1-\eta_p)(1-\eta_f)C_{out}$$

DIAGRAM 9.
UNIDIRECTIONAL FLOW BENCHES - Cleanliness calculation

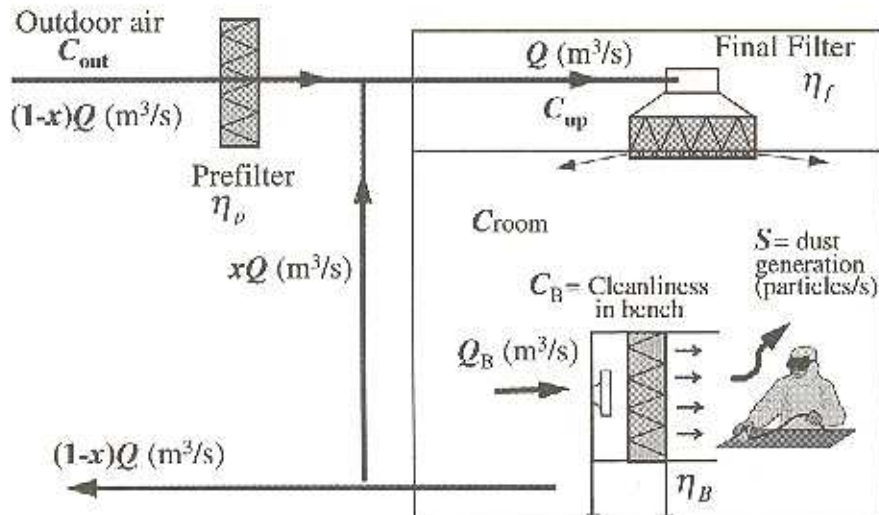

Cleanliness class in room upstream the CLEAN BENCH FILTER is approximately

$$C_{room} = S/(Q+Q_B) + (1-x)(1-\eta_p)(1-\eta_f)C_{out}$$

Cleanliness class downstream the CLEAN BENCH FILTER

$$C_B = [S/(Q+Q_B) + (1-x)(1-\eta_p)(1-\eta_f)C_{out}](1-\eta_B)$$

On world standards...

...Camfil Farr is the leader in clean air technology and air filter production.

Camfil Farr has its own product development, R&D and world wide local representation.

Our overall quality goal is to develop, produce and market products and services of such a quality that we aim to exceed our customers expectations.

We see our activities and products as an expression of our quality.

To reach a level of total quality it is necessary to establish an internal work environment where all Camfil Farr employees can succeed together. This means an environment characterised by openness, confidence and good business understanding.

www.camfil.com
info@camfil.se

**FOR FURTHER INFORMATION PLEASE CONTACT YOUR NEAREST CAMFIL FARR OFFICE.
YOU WILL FIND THE ADDRESS ON OUR WEBPAGES.**